

ALPHA EX & MIR APPROVED PETROL PUMP



Applies to the following models **ONLY**:

ALPHA...

/50WP

/70WP

/90WP

Please read carefully **BEFORE** commencing installation.

Registered Office: HYTEK (GB) LIMITED,
Delta House, Green Street, Elsenham, Bishop's Stortford,
CM22 6DS UK.

Registered in England No. 1915382

Tel: +44 (0) 1279 815 600

Email: info@hytekgb.com

ENVIRONMENTAL INFORMATION

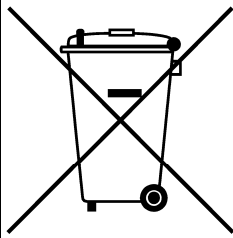

UK Regulation 2012/19/EU requires that the equipment bearing this symbol on the product and/or its packaging must not be disposed of with unsorted municipal waste. The symbol indicates that this product must be disposed of separately from regular household waste streams. It is your responsibility to dispose of this and other electric and electronic equipment via designated collection facilities appointed by the government or local authorities.

PRODUCT DESCRIPTION

This pump is ATEX certified to dispense petrol or other liquids classed as category 1, 2 or 3 in accordance with European Regulation No. 1272/2008. It bears the following certification marking and number:

MANUFACTURED TO: EN13617-1
CERTIFICATE NO: CML 17ATEX9254



This pump is MID certified in accordance with OIML to dispense diesel or other liquids in viscosity class 1. It bears the following certification marking and number:

UK/0126/0239

IMPORTANT WARNING NOTES

1. On above ground storage tanks an angle check valve fitted with the appropriate spring or pressure regulating valve must be fitted at the tank outlet to prevent loss of fuel under gravity in the event of vandalism or accidental damage.
2. This pump must only be used to dispense liquids classed as category 1, 2 or 3 in accordance with European Regulation No. 1272/2008.
3. Installation of this equipment and its associated tank, pipe work and fittings should only be carried out by qualified fuel installation engineers.
4. The installation must be carried out in accordance with the requirements of EN 60079-14 the latest relevant electrical and local authority regulations and standards.
5. It must not be used with other liquids or for other applications. We will accept no warranty claims or liability if it is used for other liquids or applications.

Temperature	:	-20°C to +45°C
Humidity	:	Class H3 (open location with average climatic conditions)
Environment	:	Open and condensing
Mechanical	:	Class M1 (location with vibration of low significance)
Electrical Disturbance	:	E1 (located in residential, commercial and light industrial environments)

CALIBRATION

The meter on this pump unit can be calibrated electronically to ensure accuracy and reliability but does have the option of being calibrated using the wheel on the side of the meter. Calibration must be carried out by a qualified Trading Standards Officer or authorised notified body in accordance with the Measuring Instruments Directive Module F.

INSTALLATION INSTRUCTIONS

1. Check you have the following items:
 - 1 off Alpha pump
 - 1 off delivery hose
 - 1 off front door key
2. Open the front panels using the key provided.
3. Remove the rear panels, if necessary, and store safely.

MOUNTING

4. Bolt the pump to a raised firm level foundation, at least 150mm in height, by means of the four 14 mm diameter-mounting holes provided. Locate the drip tray between the pump base and the foundation with the lips around the holes facing upwards.

NB: When the drip tray is fitted to the pump it must be sealed to its foundation, with a suitable elastomeric substance, to prevent leaked fuel "wicking" back underneath the pump. To maintain the environmental integrity of the drip tray any possible leak path through the pump mounting holes or the cable and pipe entry holes must also be sealed.

PIPEWORK

5. Connect the 1 1/2" diameter pipe from the tank to the suction inlet flexible connector of the pump. The inlet thread of the flexible connector flange is 1 1/2" BSP taper female. Seal the joints with a suitable thread sealing compound. The pipe work must be sealed to the drip tray (if fitted) to ensure no leaking fuel can flow underground. An alternative pipe work entry point, for above ground pipe work, is provided at the rear of the pump base. Push out the plastic cover plate if required.

NB:On above ground tanks an angle check valve fitted with the appropriate spring or an anti-syphon valve must be fitted in the suction line to prevent spillage or leakage in the event of damage.

6. Connect the delivery hose and selected ATEX approved nozzle to the pump outlet in accordance with the instructions supplied with the individual components. Ensure the nylon hose-sealing washers are in place on the hose end. It should be hand tight plus a quarter turn.

ELECTRICAL

7. Remove the covers from the junction box.
8. Connect a constant 220/240V AC 50 Hz supply, fused at 16 amps, to the terminal block in the junction box as shown on the wiring details diagram.

NB: The Alpha pump must have a continual 220/240V AC supply, even when not in use

9. If the Alpha is to be operated in conjunction with a key/card system, it must be connected via the Hytek Modbus RS485 protocol. Connections are provided in the junction box and are labelled accordingly. Connection must be made using a suitable screened cable.
11. Ensure all the terminal screws are tight and replace the junction box covers.

INSTRUCTIONS FOR USE

1. Remove the nozzle from the holster.
2. Place the nozzle spout in the fuel tank.
3. Squeeze the nozzle trigger to dispense fuel.

On completion of the delivery release the trigger and replace the nozzle in the holster.

MAINTENANCE

The Alpha should require minimum maintenance in normal regular use, but as with all mechanical apparatus regular servicing will prolong its life and ensure maximum efficiency & reliability.

The following should be carried out every 12 months or 1 million litres whichever ever comes first.

- **Isolate power supply**
- **Inspect & clean or replace pump filter**
- **Inspect & clean or replace nozzle filter**
- **Inspect & replace if necessary the V-belt**
- **Check motor pulley grub screw is tight**
- **Re-calibrate electronic display**

ALPHA BASE AND SUCTION CONNECTION DIAGRAMS

BASE VIEW FROM ABOVE

ALL DIMENSIONS IN MM

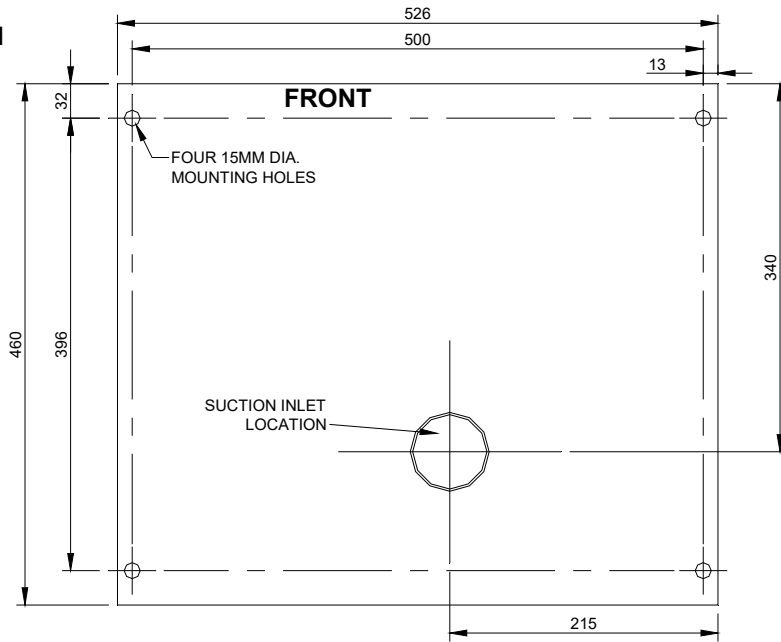

REAR VIEW

1 1/2" STAINLESS STEEL FLEXIBLE CONNECTOR (SUPPLIED AS STANDARD)

1 1/2" BSP TAPER FEMALE THREADED STANDARD TRIANGULAR SUCTION FLANGE ALIGNED WITH SUCTION HOLE IN BASE

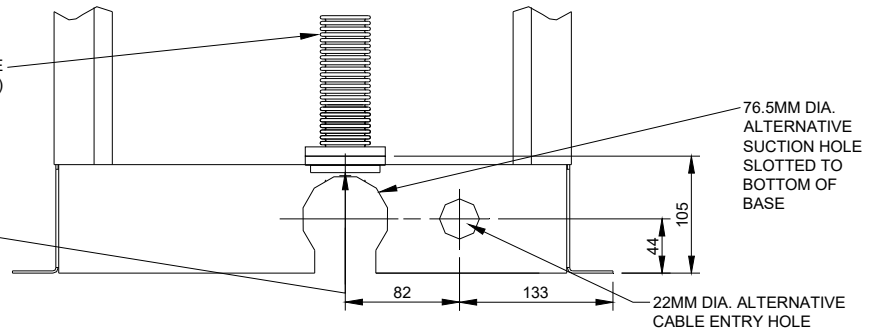

ALPHA INSTALLATION WIRING DIAGRAM

MAINS / 230VAC JUNCTION BOX CONNECTIONS

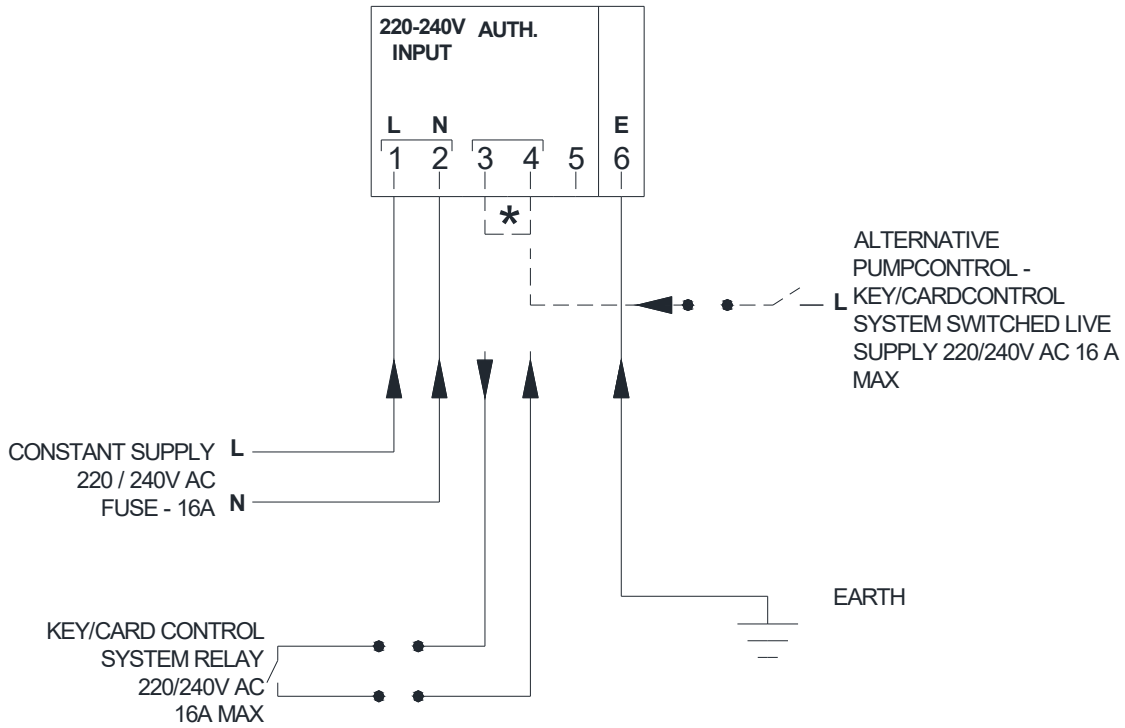

* SUPPLIED WITH LINK FITTED BETWEEN TERMINALS 3 AND 4.
REMOVE LINK FOR REMOTE KEY/CARD CONTROL

LOW VOLTAGE / SIGNAL JUNCTION BOX CONNECTIONS

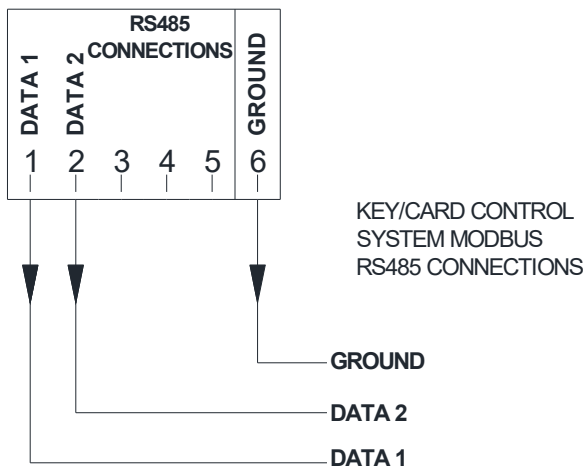

ALPHA EXTERNAL DIMENSIONS



ELECTRONIC DISPLAY/CALCULATOR

FEATURES

6-digit backlit Main LCD display: Up to 9999.99 or 99999.9 litres per delivery

8-digit backlit totaliser LCD display: Up to 99999999 litres

Display retained during power failure

OPERATION

Stand-by mode: Upper line of LCD display shows previous delivery
Lower line of LCD display shows ongoing total

Nozzle removed: Upper line shows "all eights" then "all zeros"
Lower line shows "FUELLING"
Pump starts

Fuel drawn: Upper line shows litres dispensed
Lower line shows "FUELLING"

Nozzle Returned: Pump stops
Upper line of LCD display shows previous delivery
Lower line of LCD display shows ongoing total

CALIBRATION PROCEDURE - (MUST BE CARRIED OUT TO ENSURE PUMP ACCURACY)

1. Ensure the nozzle is stowed in the holster and the dispenser is isolated from any fuel management systems.



2. Remove calibration button cover bolt from rear of display / calculator housing (if fitted).

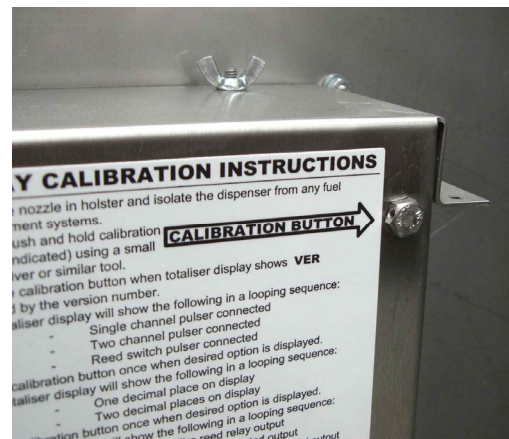

3. Gently push and hold the calibration button using a small screwdriver or similar tool.



4. Release the calibration button when the totaliser display shows **VER** followed by the version number on the lower line of the display.



5. The lower line will show the following in a looping sequence:
1 PULSE CHANNEL - Single channel pulser connected
2 PULSE CHANNEL - Two channel pulser connected
REED PULSER - Reed switch pulser connected

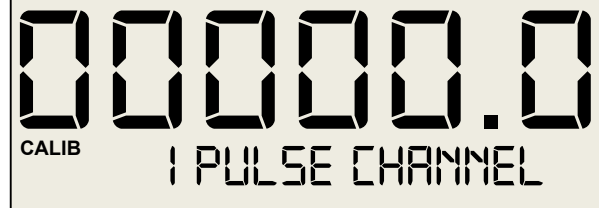

Press calibration button once when desired option is displayed.
Select **2 PULSE CHANNEL** for MID/OIML Alpha, **REED PULSER** for Alpha fitted with PULS.E18 reed switch pulser (pre-August 2003) or Adblue™ Alpha and **1 PULSE CHANNEL** for all other Alpha versions.

6. The lower line will show the following in a looping sequence:
LITRES – Display measures in litres.
GALLONS – Display measures in gallons (Imperial or US)
Press calibration button once when desired option is displayed.



7. The lower line will show the following in a looping sequence:
BACKLIGHT ON – backlight on constantly.
BACKLIGHT OFF – backlight off.
ON FOR FUELLING – backlight only on during fuelling.
Press calibration button once when desired option is displayed.

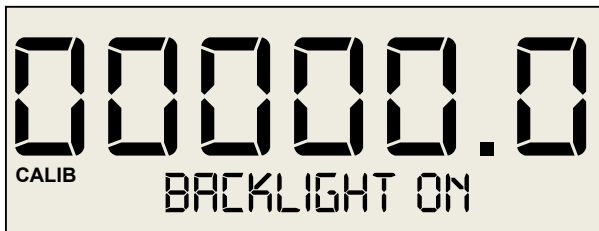

8. The lower line will show the following in a looping sequence:

1 DECIMAL PLACE - One decimal place on display

2 DECIMAL PLACE - Two decimal places on display

Press calibration button once when desired option is displayed.

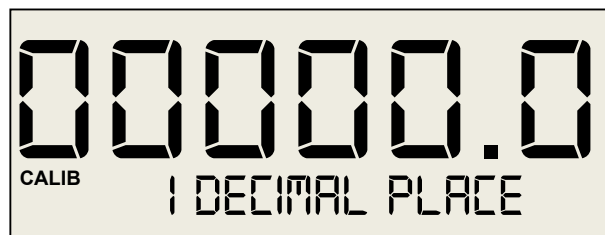

9. The lower line will show the following in a looping sequence:

REED RELAY 10 - Ten pulse per litre reed relay output.

OPTO OUTPUT 10 - Ten pulse per litre opto-isolated output.

OPTO OUTPUT 100 - One hundred pulse per litre opto-isolated output.

Press calibration button once when desired option is displayed.



10. The lower line will show the following in a looping sequence:

TANK SW UNUSED - No “tank empty” switch connected. **SELECT THIS OPTION FOR MID APPROVED DISPENSER.**

TANK SW IS TA.F - “Tank empty” switch connected is Hytek TA.F type* (*Feature coming soon)

TANK SW NOT TA.F - “Tank empty” switch connected is standard “normally closed” float switch* (*Feature coming soon)

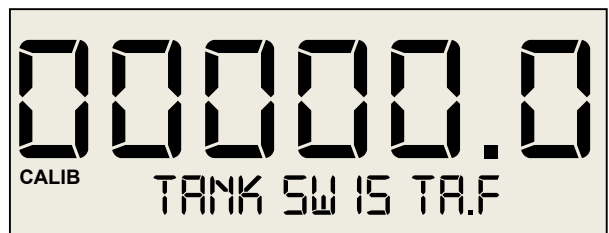

11. The lower line will show the following in a looping sequence:

LEAK SW UNUSED – No “pump leak” switch connected. **SELECT THIS OPTION FOR MID APPROVED DISPENSER.**

LEAK SW IS TA.F – “pump leak” switch connected is Hytek TA.F type

LEAK SW NOT TA.F – “pump leak” switch connected is standard “normally open” float switch

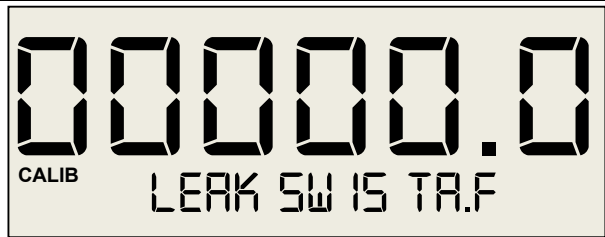

12. The lower line will show the following in a looping sequence:

NOZ 2 SW UNUSED – No additional /remote nozzle switch connected. **SELECT THIS OPTION FOR MID APPROVED DISPENSER.**

2nd NOZ SW N/O– Additional nozzle switch is normally open type.

2nd NOZ SW N/C – Additional nozzle switch is normally closed type.

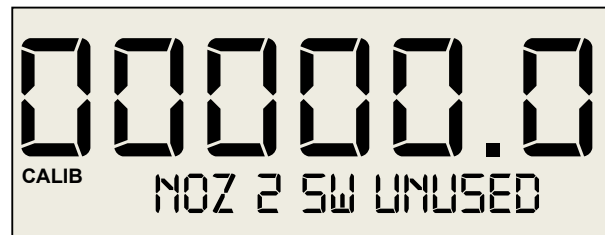

13. The lower line will show the following in a looping sequence:

STAND ALONE - Pump external serial interface not used.

NETWORK – Pump connected to a network via the RS485 output.

MANAGED – Pump managed using the MODBUS protocol via the RS485 output. **SELECT THIS OPTION FOR MID APPROVED DISPENSER CONNECTED TO AN MID APPROVED FUEL CONTROL SYSTEM.**



If **STAND ALONE** was selected in 13. above proceed to 18. If **MANAGED** was selected proceed as follows.

14. The lower line will show the following in a looping sequence:

MODBUS RTU – Select this option if the pump is connected to a Hytek FC20 or a Fueltek FT4000 control system.

MODBUS ASC II – Select this option for an alternative Modbus option.

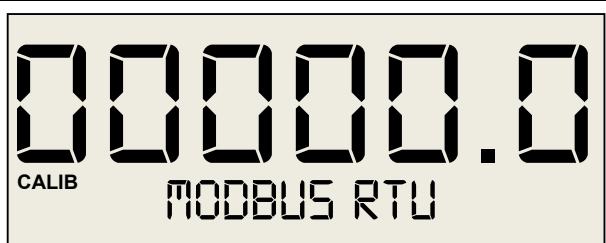

15. The lower line will show the following in a looping sequence:

BAUD RATE 9600

BAUD RATE 19200

BAUD RATE 38400

Select the required Baud rate. Select **38400** if the pump is connected to a Fueltek fuel control system.

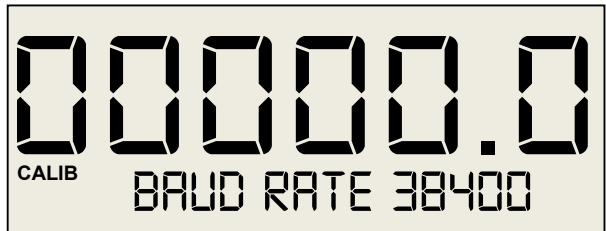

16. The lower line will show the following in a looping sequence:

NO PARITY, EVEN PARITY and **ODD PARITY**

Select the required parity. Select **NO PARITY** if the pump is connected to a Fueltek fuel control system.



17. The lower line will show **ADDRESS 001** with the first numerical digit counting up to 3 and then back to 0 in a looping sequence. Select the required first digit of the pump address in the managed network. Repeat with the second and third digits which count up to 9.



18. The lower line will show the following in a looping sequence:

SAVE AND EXIT – Save all settings entered and return to normal operation.

CALIBRATE PUMP – Continue and calibrate pump with 20 litre measure.

ABANDON CONFIG – Do not save any settings entered and return to normal operation.



19. If **CALIBRATE PUMP** was selected **TAKE NOZZLE** will be shown.

Take the nozzle (the lower line will show **DISPENSE 20L**) and dispense 20 litres into a calibrated test measure.



20. Once 20 litres have been dispensed hang up the nozzle. The lower line should show **CALIBRATION OK**. If there is an error in the calibration the relevant error message will be displayed.



ERRORS

If an error occurs **ERROR**, followed by a brief description is shown on the lower display. The errors are classified as follows:

FLOW TOO FAST The pulser has run too fast (in excess of 300 pulses per second)

UNAUTH FLOW The meter has turned without the nozzle being removed

CALIBRATE FAIL A time delay of 2 minutes or more has occurred during the 20-litre calibration.

PULSER SIGNAL One of the pulse transmitter's pulse trains has been interrupted.

PULSE REVERSE The meter has run backwards during a delivery

PULSER POWER The pulser has been disconnected

The error condition is maintained until the nozzle is returned to its holster, for at least 2 seconds, and then removed again to restart the fuelling sequence.

TIMEOUT

If, during a delivery, no fuel is dispensed for 2 minutes the display will show **TIMEOUT** alternating with **REPLACE NOZZLE** and the pump will stop running until the nozzle is returned to its holster, for at least 2 seconds, and then removed again to restart the fuelling sequence.

DISPLAY CONNECTION DIAGRAM

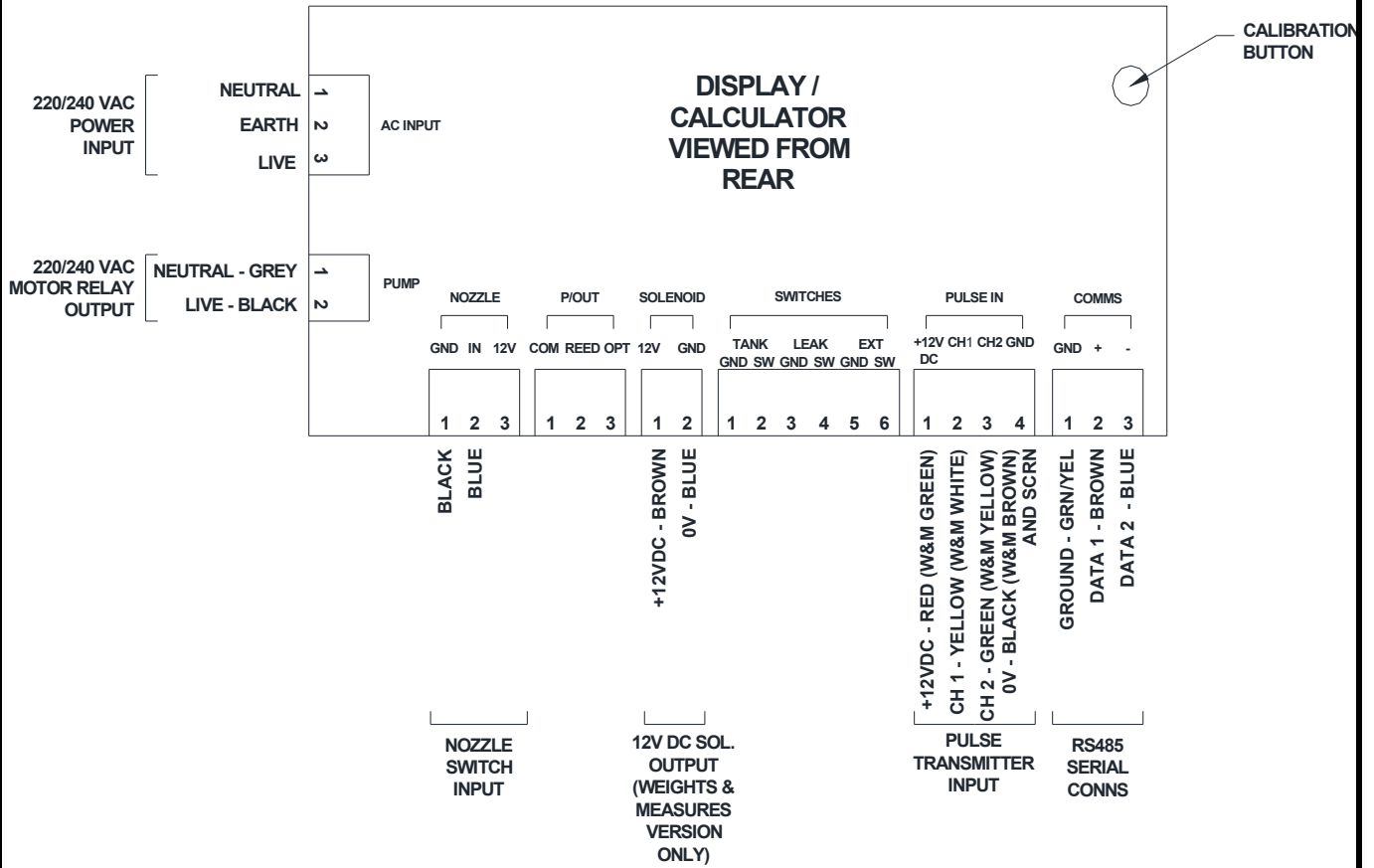

ALPHA EXTERNAL VIEW

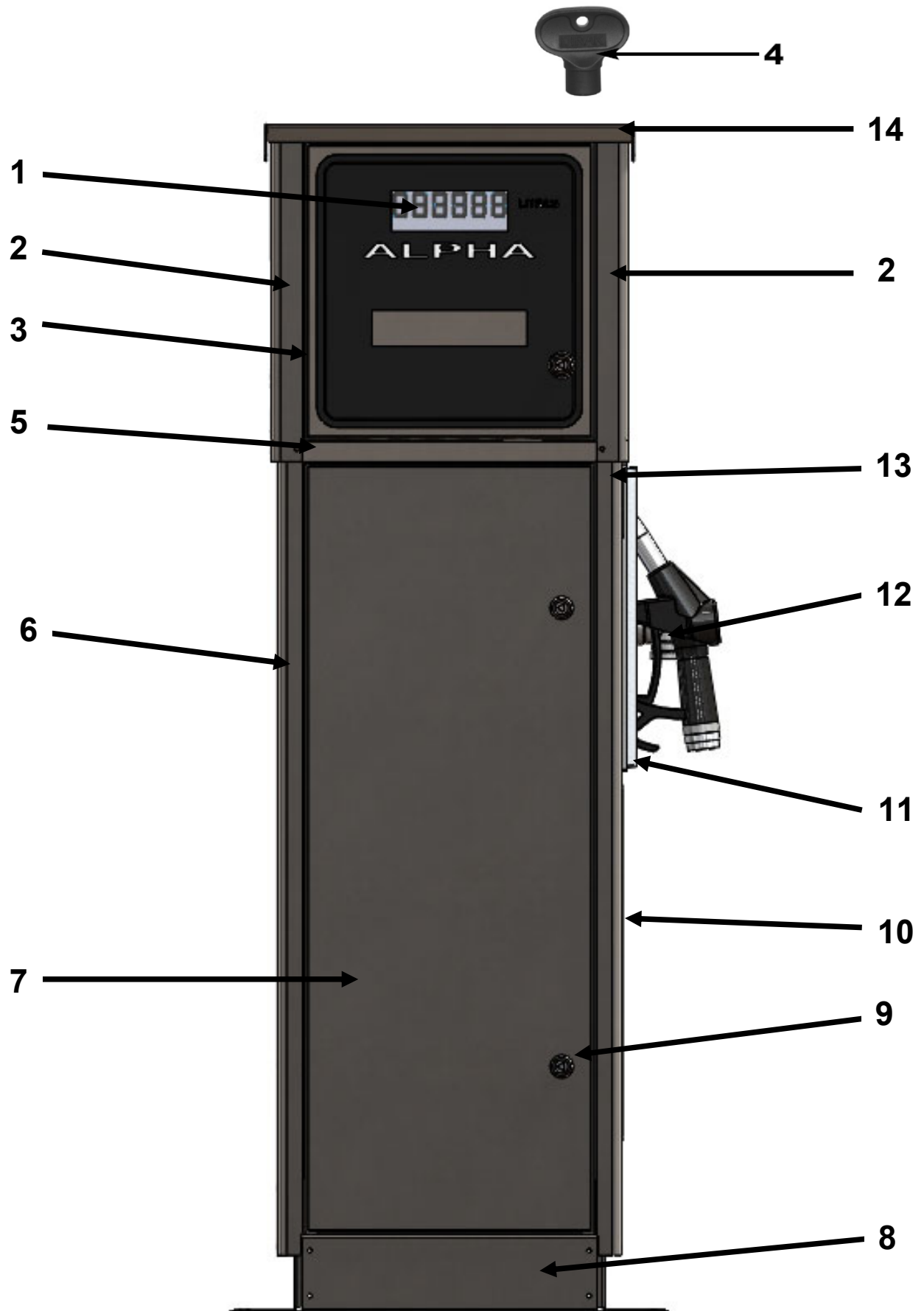

ALPHA INTERNAL VIEW

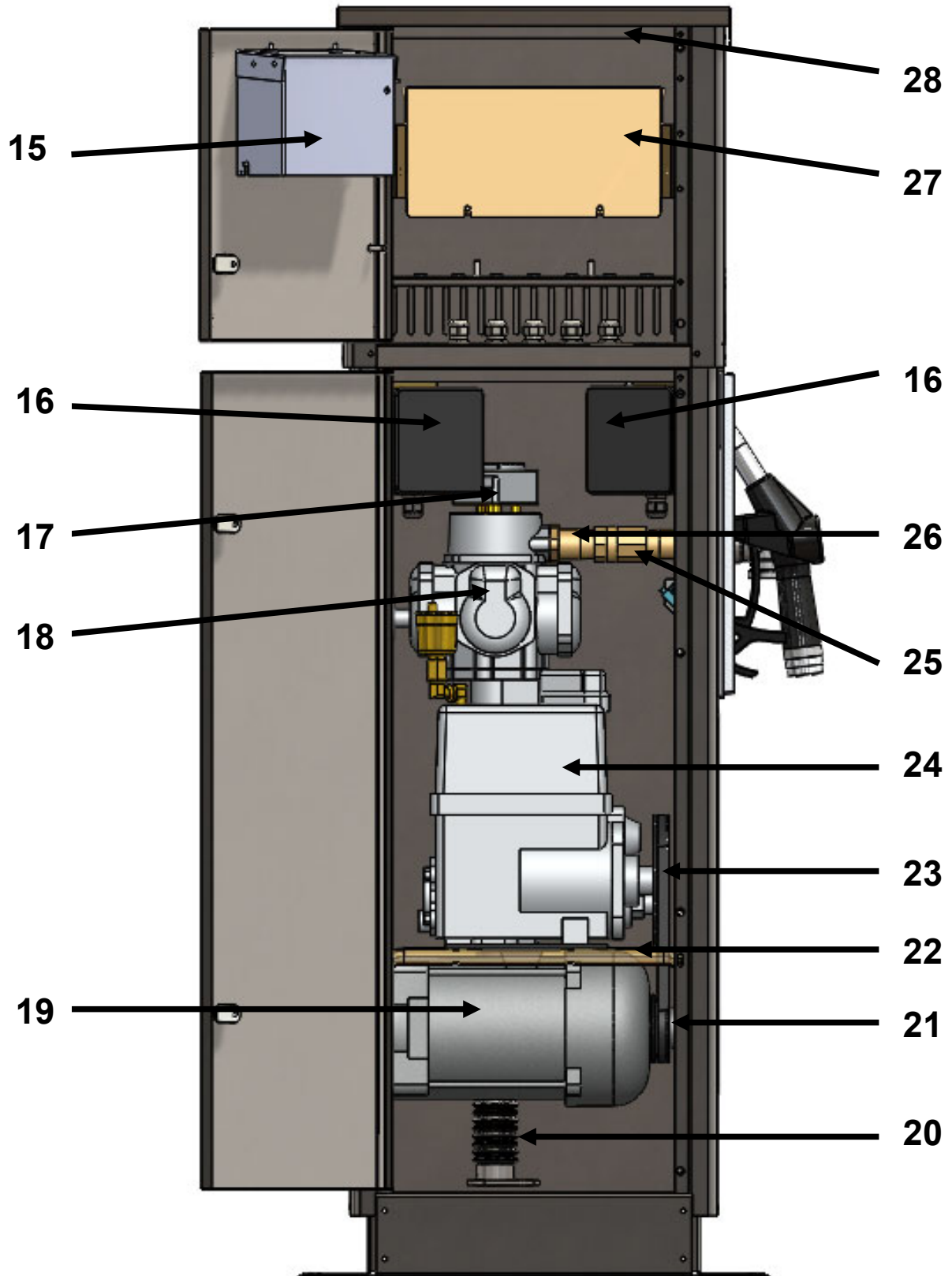

ALPHA SIDE ACCESS PANEL VIEW

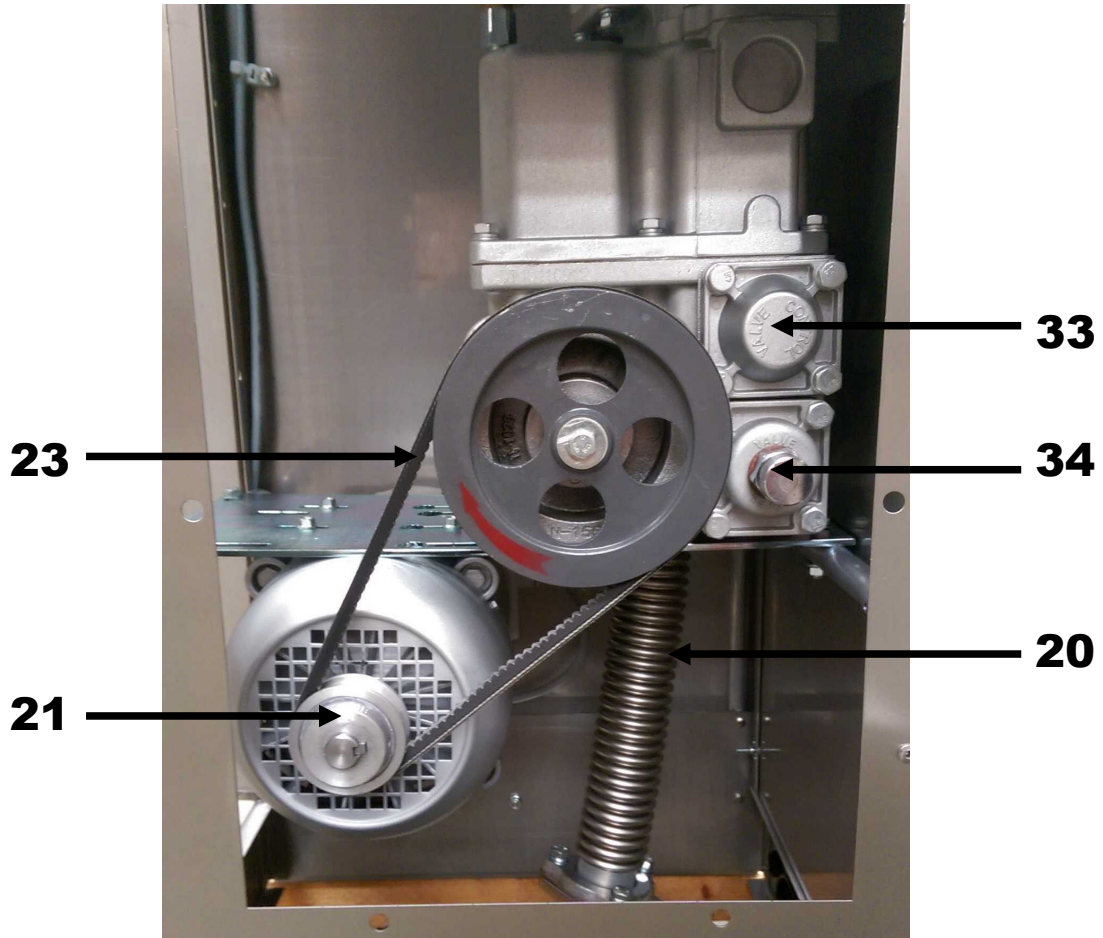

ALPHA PUMP UNIT FILTER LOCATION

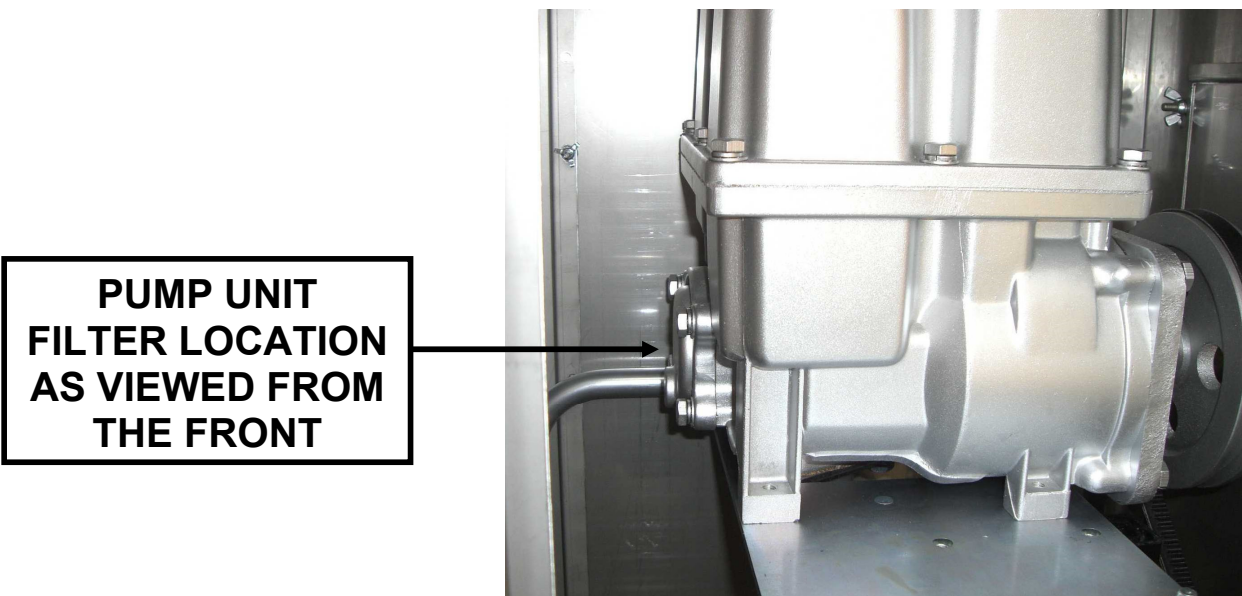

ALPHA PARTS LIST

DRG. REF	PART DESCRIPTION	PART NO. 50WP	PART NO. 70WP
	EXTERNAL COMPONENTS		
1	LCD DISPLAY UNIT (Above item includes LCD, transformer board and fitting kit)	ALP.DISP.PCB.3A	ALP.DISP.PCB.3A
2	SIDE PANEL (UPPER CABINET)	ALP.SPAN.E4	ALP.SPAN.E4
3	UPPER DOOR	ALP.DOOR.E4	ALP.DOOR.E4
4	DOOR KEY	209.KEY	209.KEY
5	LOWER CABINET CAP	ALP.CAP.H4	ALP.CAP.H4
6	SIDE PANEL (LOWER CABINET)	ALP.SPAN.BL4	ALP.SPAN.BL4
7	LOWER DOOR	ALP.DOORH4	ALP.DOORH4
	LOWER DOOR (FRONT NOZZLE OPTION)*	ALP.DOORHF4	ALP.DOORHF4
8	MOUNTING BASE	ALP.BASE3	ALP.BASE3
9	LOCK (x 3)	ALP.LOCK3	ALP.LOCK3
10	SIDE ACCESS PANEL	ALP.ACPCAN3	ALP.ACPCAN3
11	NOZZLE HOLSTER WITH SWITCH	ALP.NOZBOOT.P	ALP.NOZBOOT.P
12	OUTLET ELBOW	ELB.4FFCR	ELB.4FFCR
13	SIDE PANEL WITH HOSE OUTLET	ALP.SPAN.H4	ALP.SPAN.H4
	SIDE PANEL WITH HOSE OUTLET (FRONT NOZZLE OPTION)	ALP.SPAN.HF4	ALP.SPAN.HF4
14	TOP CAP	ALP.CAP4	ALP.CAP4
	INTERNAL COMPONENTS		
15	DISPLAY COVER	ALP.DISPCOV3A	ALP.DISPCOV3A
16	MAINS/230VAC JUNCTION BOX	ALP.JBOX.P	ALP.JBOX.P
17	PULSER	PULS.W	PULS.W
18	4 PISTON METER (2 REV PER L)	209A.METER.REP	209A.METER.REP
19	MOTOR	MOT.E75.ATEX	MOT.E75.ATEX
20	FLEXIBLE SUCTION CONNECTOR	TTLB	TTLB
21	PULLEY	PULL.2C	PULL.25C
22	PUMP MOUNTING FRAME (x 2)	ALP.PFRAME3	ALP.PFRAME3
23	PULLEY BELT	VBLT.275	VBLT.28
24	PUMP UNIT (COMPLETE)	209A.PASSY.W	209A.PASSY.W
25	SOLENOID VALVE	ALP.SOL.A	ALP.SOL.A
26	METER OUTLET PIPE	ALP.OUTPIPE.W	ALP.OUTPIPE.W
27	JUNCTION BOX	ALP.DBOX3	ALP.DBOX3
28	UPPER PANEL (x 2)	ALP.UPAN4	ALP.UPAN4
29	INLET FLANGE*	FLNG	FLNG
30	INLET GASKET*	GSK.TRI.P	GSK.TRI.P
31	RELAY (INSIDE JUNCTION BOX)*	ALP.RELAY	ALP.RELAY
32	PUMP MOUNTING PLATE*	ALP.PPLATE3C	ALP.PPLATE3C
33	CHECK VALVE*	209EP.21	209EP.21
34	BYPASS VALVE*	209EP.29	209EP.29
35	PUMP UNIT FILTER*	209EP.3	209EP.3
36			

*Not shown on illustration

DECLARATION OF CONFORMITY



Company Name: **Hytek (GB) Ltd**
Address: **Delta House, Green Street. Elsenham,
Bishops Stortford, Hertfordshire, CM22 6DS, UK**

Date of Issue: **1st January 2021**

Equipment Details: **Alpha ATEX Fuel Pumps, MID Approved
ALPHA/50WP, ALPHA/70WP, ALPHA/90WP**

Applicable Directives:
& Standards

SI 2016 1091 Electromagnetic Compatibility Regulations

SI 2016 1101 Electrical Equipment Safety Regulations

SI 2008 1597 Supply of Machinery Safety Regulations

SI 2016 1105 Pressure Equipment Safety Regulations

SI 2013 3113 Waste Electrical & Electronic Equipment Regulations

**SI 2012 3032 Restriction of Use of Certain Hazardous Substances
Regulations**

2014/34/EU ATEX Directive
EN 13617-1:2012 & EN 1127-1:2019

EC Type examination Certificate
Number: CML 17ATEX9254
Issued by Notified Body: CML Ltd. Number 2503
Unit 1 Newport Business Park, New Port Rd
Ellesmere Port, CH65 4LZ UK

Marking: Ex II 2 G
EN 13617-1:2012
Ta= -20°C to + 40°C

Notified Body Issuing QA: CML B.V Number 2776
Notification Certificate Chamber of Commerce No 6738671
Hoogoorddreef 15, Amsterdam, 1101 BA,
The Netherlands

2016 SI 1153 Measuring Instruments Regulations
Type Examination Certificate No.: UK/0126/0239
Approved Body: NMO Number 0126
Stanton Ave, Teddington TW11 0JZ

Declaration Number: **UK143/6**

On behalf of the above-named company, I declare under our sole responsibility that, on the date the equipment accompanied by this declaration is placed on the market, the equipment conforms with all technical and regulatory requirements of the above listed directives.

Clive Wellings, Technical Manager, 22nd September 2020, Bishops Stortford, Herts.

THE INFORMATION CONTAINED IN THIS DOCUMENT IS PROTECTED BY COPYRIGHT © AND PROPERTY LAWS AND IS THE SOLE PROPERTY OF HYTEK (GB) LTD. ANY REPRODUCTION IN PART OR AS A WHOLE WITHOUT THE WRITTEN PERMISSION OF HYTEK (GB) LTD IS PROHIBITED.