

ANTI-SIPHON VALVE

USE

The anti-siphon valve ensures the smooth running of all distributor pumps working from overhead tanks (maximum height 6m). It avoids the overpressure in the air separator and siphoning of the tank.

TECHNICAL CHARACTERISTICS

The helicoidal racks of the valve is designed to favour the progressive opening and then regulates flow.

A filter prevents valve mechanism from impurities.

This valve makes minimum head loss.

Only design ND 40 (1" ½). Manufactured in corrosion resistant cadmium steel-bronze valve – special hydrocarbon joins.

MOUNTING INSTRUCTIONS/ MAINTENANCE

- No other anti-return valve shall be installed on the aspiration pipe.
- The way flow is indicated under the cap by an arrow.
- The anti-siphon valve must be installed on the main delivery line from the tank and as close to the distributor pump taking care not to obstruct the air hole of the cap.
- All servicing and maintenance work on the valve can be carried out without disconnected fuel lines by installing shut off valves for any maintenance work.
- A screw adjustment under the valve controls the valve to the flow rate and avoids any knocking phenomenon.
- The internal filter must be regularly cleaned which is on the inlet side of the valve.

SPARE PARTS

REFERENCE	DESCRIPTION
1 30 00 110	Diaphragm
1 30 01 070	Screws and O rings blister
1 30 01 020	Valve and seat set

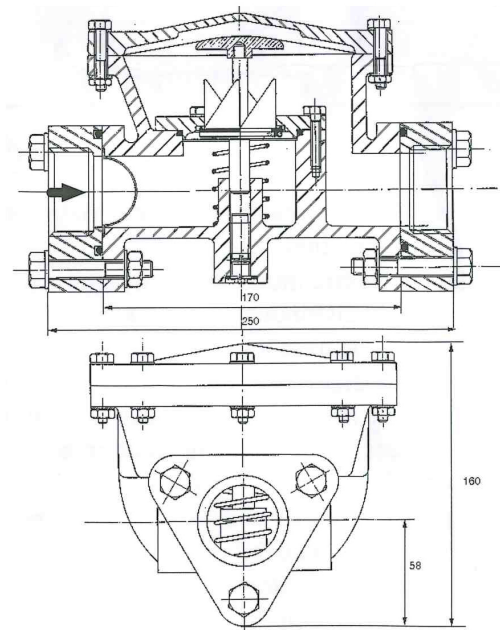
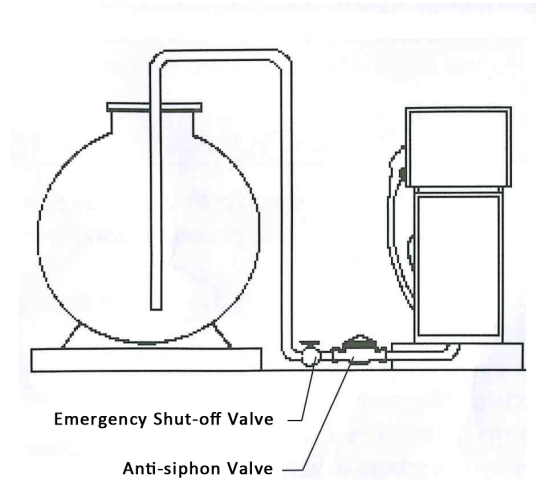

(dimensions in mm)

Ref: 13000000

FACTORY TESTED PRODUCT